

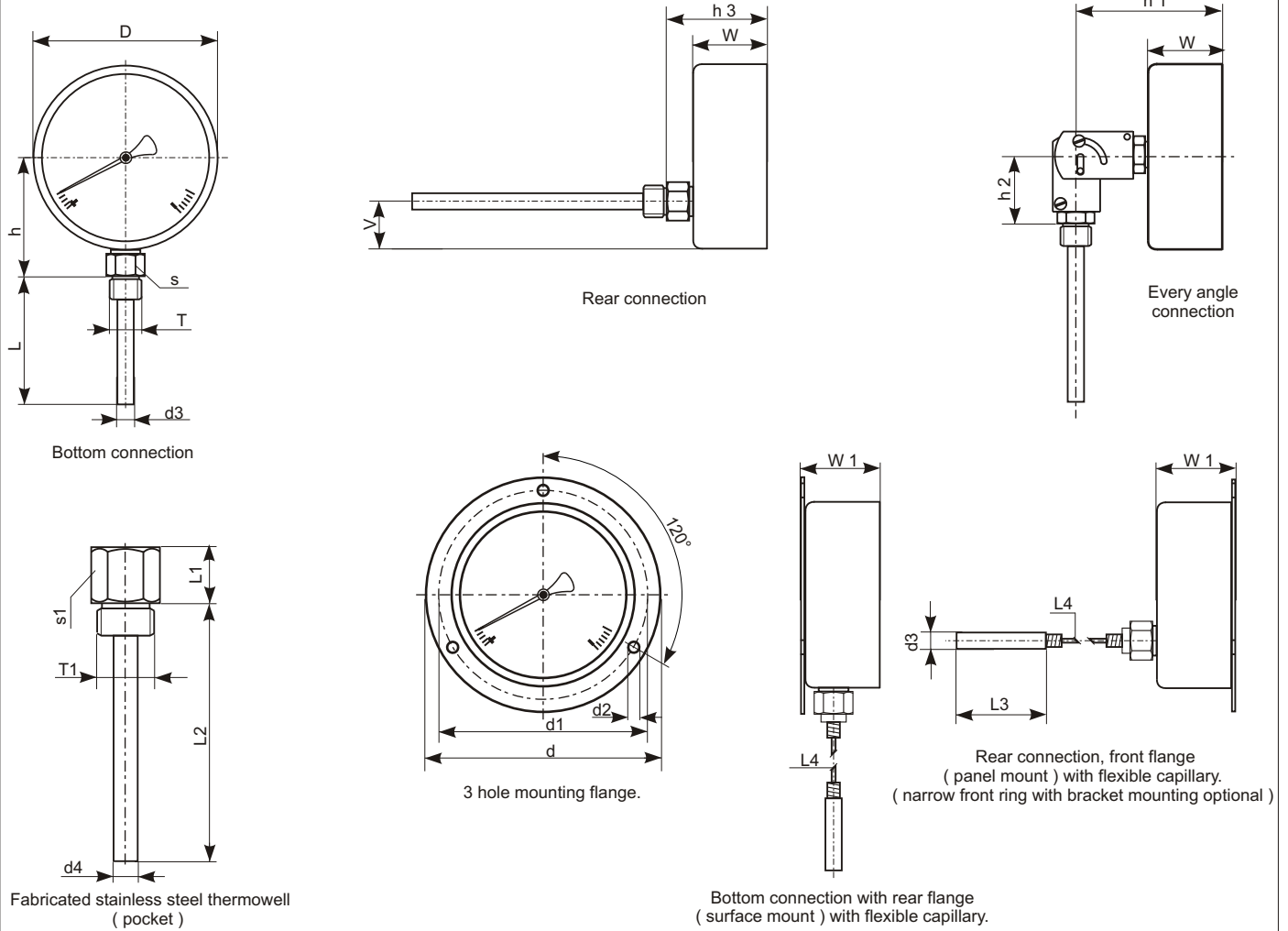

GAS - IN METAL THERMOMETER DIMENSIONS

Type G4: All stainless steel construction

DIMENSIONS OF GAS - IN METAL THERMOMETERS AND THERMOWELLS



GAS - IN METAL THERMOMETER DIMENSIONS																	Weight in kg			
(in mm)																	Dry	Glyc filled		
Case Ø	D	d	d1	d2	d3	h	h1	h2	h3	L	L3	L4	s	T	V	W	W1			
100	100	132	116	4.8	12mm dia	70	100	47	70	Standard lengths 100, 150, 200, 250 & 300mm.	150mm standard. Other lengths on req.	Capillary length on request, up to 30m	22 Hex 22 Hex 22 Hex	Standard 1/2" BSP / NPT. Other sizes on request.	28 42 92	50 50 50	51.2 51.2 51.2	0.7 1 1.2	1 1.7 NA	
150	150	196	178	5.8	standard.	95	100	47	70											
250	250	290	270	5.8	6, 8 & 10mm dia on request.	145	100	47	70											
										Non standard & other lengths up to 2m available on request.										

FABRICATED THERMOWELL DIMENSIONS (SOLID MACHINED ON REQUEST)				
(in mm)				
d4	L1	L2	s1	T1
16	25	Standard lengths: 80, 130, 180, 230, 280mm Non standard lengths & other specifications on request.	27 Hex	1/2" BSP / NPT male thread standard. Other specifications on request.

Due to continuous product development, product might vary from brochure. Please contact S.A Gauge to verify.