

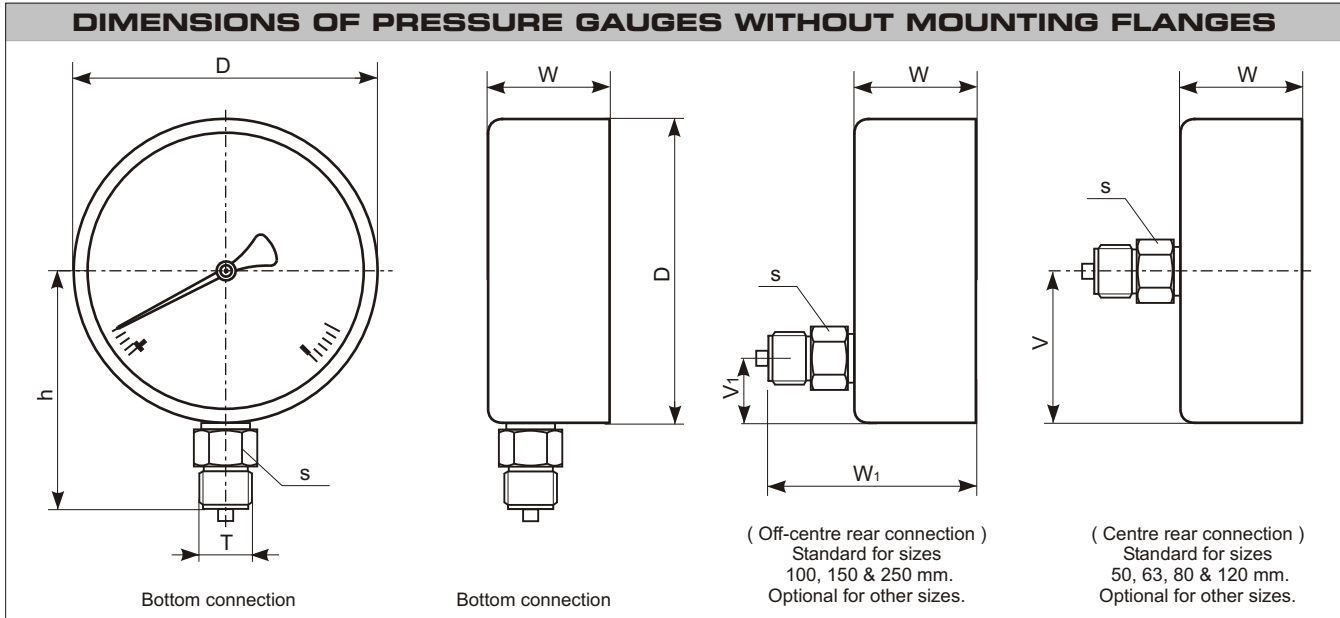

INDUSTRIAL PRESSURE GAUGE DIMENSIONS
General purpose industrial use
Type 3: Stainless steel case with brass internals
Type 4: Stainless steel case with stainless steel internals

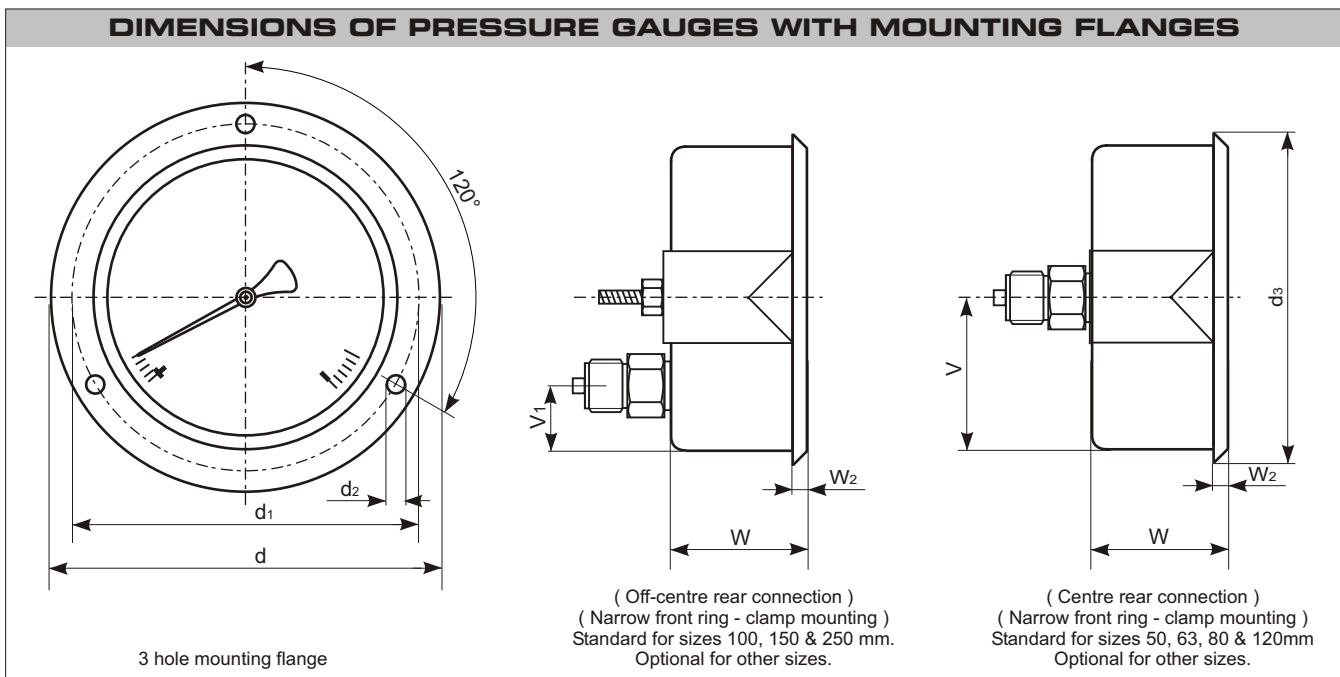

PRESSURE GAUGE CASE & FLANGE DIMENSIONS (in mm)													Panel cut out to suit back entry gauges		Weight in kg		
Case Ø	D	d	d1	d2	d3	h	s	T	V	V1	W	W1	W2	3 Hole MTG	Clamp MTG	Dry	Glyc filled
50	50	70	60	3.6	59	49	14 Hex	1/8", 1/4" BSP / BSPT / NPT standard (3/8", 1/2" BSP / BSPT / NPT and other threads on request.)	25	NA	31.5	55.5	4	55	51	0.15	0.2
63	63	84	75	3.6	73	55	14 Hex		31.5	12	35.5	59.5	4	68	64	0.2	0.3
80	80	110	95	4.8	90	64	14 Hex		40	20	37	61	4	86	81	0.3	0.55
100	100	132	116	4.8	110	89	22 Hex	1/4", 3/8", 1/2" BSP / BSPT / NPT standard (Other thread sizes on request.)	50	28	50	89	4	106	101	0.5	0.8
120	120	151	135	4.8	130	99	22 Hex		60	NA	37	76	3	123	121	0.5	0.8
150	150	196	178	5.8	163	114	22 Hex		NA	42	47	86	3	157	151	0.8	1.5
250	250	290	270	5.8	263	164	22 Hex		NA	92	50	89	3	253	251	1kg	NA



Due to continuous product development, product might vary from brochure. Please contact S.A Gauge to verify.